

SUBJECT TO TECHNICAL ALTERATIONS

SCALE 1:2

TYPE: Intertest PRICECLASS: 25
RANGE OF APPLICATION: 4.0" - 6.0"
SCALE INTERVAL: .001"

MEASURING FORCE: 1.2" - 2.0"
WEIGHT: 485g

ACCEPTABLE DEVIATIONS (VDI/VDE/DGQ 2618 Bl. 12.1/13.1)

MAX. PERMISSIBLE ERRORS $G = .003$ "
REPEATABILITY $r = .001$ "

REFERENCE TEMPERATURE: 20°C
OPERATION TEMPERATURE: 10°C - 30°C
STORAGE TEMPERATURE: -10°C - 50°C

SHAPES OF CONTACTS

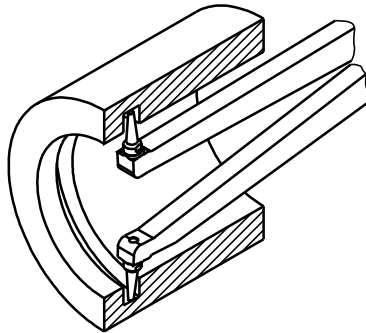

HM-BALLS ϕ .079"

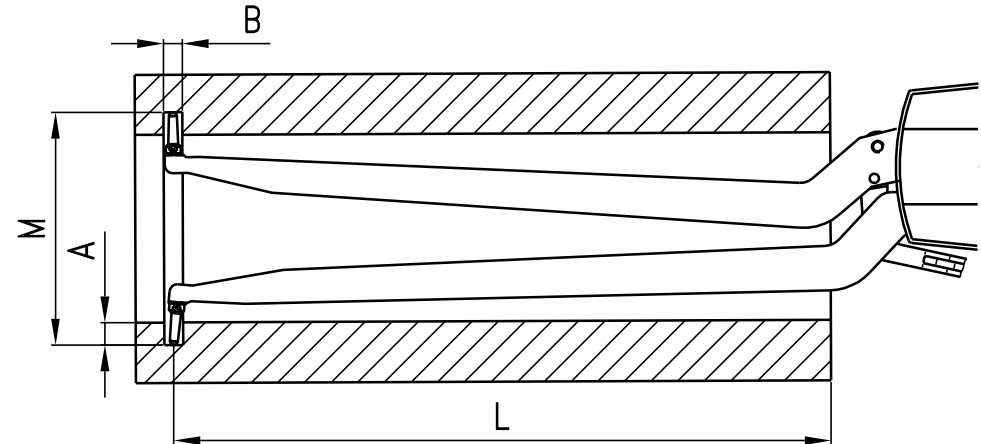

GROOVE DEPTH A [inch]	MEASURING RANGE M [inch]										
	3.937	4.094	4.252	4.409	4.567	4.724	4.921	5.118	5.315	5.512	5.906
0	0/6.496	0/6.811	0/6.969	0/7.047	0/7.047	0/7.047	0/7.047	0/7.047	0/7.047	0/7.047	0/7.047
.039		.094/6.772	.094/6.929	.094/7.008	.094/7.047	.094/7.047	.094/7.047	.094/7.047	.094/7.047	.094/7.047	.094/7.047
.079		.098/6.732	.098/6.890	.098/6.969	.102/7.047	.102/7.047	.102/7.047	.102/7.047	.102/7.047	.102/7.047	.102/7.047
.118			.102/6.850	.102/6.929	.106/7.047	.106/7.047	.106/7.047	.110/7.047	.110/7.047	.110/7.047	.110/7.047
.157			.110/6.772	.110/6.890	.110/7.047	.110/7.047	.110/7.047	.114/7.047	.114/7.047	.114/7.047	.118/7.047
.197				.118/6.850	.118/7.008	.114/7.047	.114/7.047	.122/7.047	.122/7.047	.122/7.047	.126/7.047
.236				.122/6.811	.122/6.969	.122/7.047	.122/7.047	.126/7.047	.126/7.047	.130/7.047	.134/7.047
.276					.126/6.929	.126/7.008	.126/7.047	.134/7.047	.134/7.047	.138/7.047	.142/7.047
.315					.130/6.890	.130/6.969	.134/7.047	.142/7.047	.142/7.047	.146/7.047	.150/7.047
		B/L									

B = MINIMUM GROOVE WIDTH [inch]

L = MAXIMUM USABLE ARM LENGTH [inch]

EXAMPLE: M= 4.409" > B= .102"
 A= .188" > L= 6.929"

ACCESSORIES

-WOODEN CASE
 ORDER NO.: 1732-30

SPARE PARTS

-COVERING GLASS OF
 THE SCALE
 ORDER NO.: 0450-08

-MEASURING CONTACT
 ORDER NO.: 0251-02

-HANDLE
 ORDER NO.: 0450-13

